

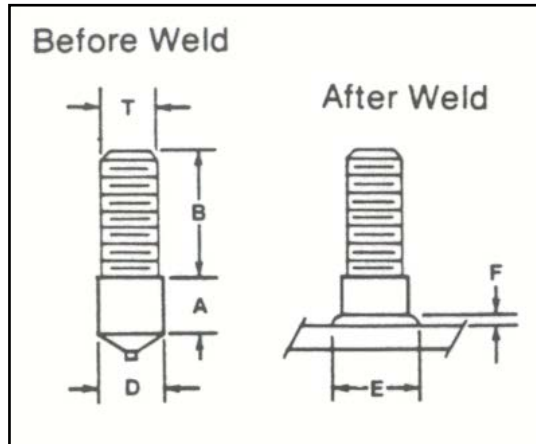

ALUMINUM STANDARD STUDS



SUNBELT aluminum standard studs are partially threaded with a weld base diameter greater than the thread diameter.

Typical Use: Most applications requiring full strength in weld base area.

Length Specifications: Lengths available as specified to a maximum of 2-13/16" nominal, 3" BW. Establish overall length by the combination of dimensions A and B.

Material: Aluminum alloy 5000 Series.

Ferrules: All orders include ferrules, which are supplied with the studs and are not sold individually.

To Order: Specify stud type, quantity, **D**, **A(BW)**, **B**, material.

SPECIFICATIONS						
THREAD SIZE T	WELD BASE DIA. (NOM.) D	UNTHREADED LENGTH		MAX THREADED LENGTH B	APPROXIMATE WELD BEAD DIMENSIONS	
		BEFORE WELD A(BW)	AFTER WELD (NOM.) A(AW)		DIA. E	HGT. F
10-32	1/4	5/16	1/8	2-1/2	13/32	1/8
1/4-20	5/16	3/8	3/16	2-1/2	15/32	5/32
5/16-18	3/8	13/32	7/32	2-1/2	5/8	3/16
3/8-16	7/16	15/32	9/32	2-1/2	21/32	7/32
7/16-14	1/2	1/2	5/16	2-1/2	3/4	1/4

www.sunbeltstudwelding.com

Sunbelt Stud Welding, Inc
6381 Windfern Road
Houston, Texas 77040-4915



1-800-462-9353
713-939-8903
fax 713-939-9013