

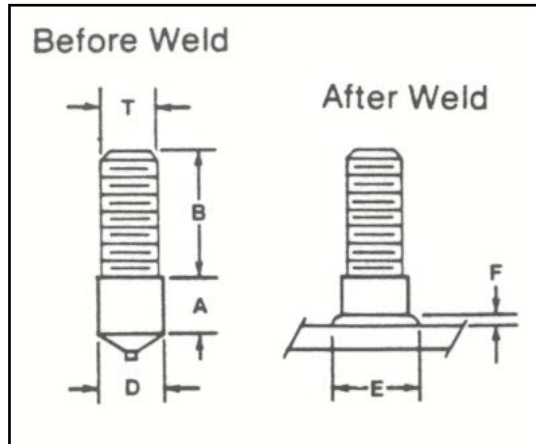

# ALUMINUM STANDARD STUDS



SUNBELT aluminum standard studs are partially threaded with a weld base diameter greater than the thread diameter.

**Typical Use:** Most applications requiring full strength in weld base area.

**Length Specifications:** Lengths available as specified to a maximum of 2-13/16" nominal, 3" BW. Establish overall length by the combination of dimensions A and B.

**Material:** Aluminum alloy 5000 Series.

**Ferrules:** All orders include ferrules, which are supplied with the studs and are not sold individually.

**To Order:** Specify stud type, quantity, **D**, **A(BW)**, **B**, material.

SPECIFICATIONS						
THREAD SIZE <b>T</b>	WELD BASE DIA. (NOM.) <b>D</b>	UNTHREADED LENGTH		MAX THREADED LENGTH <b>B</b>	APPROXIMATE WELD BEAD DIMENSIONS	
		BEFORE WELD <b>A(BW)</b>	AFTER WELD (NOM.) <b>A(AW)</b>		DIA. <b>E</b>	HGT. <b>F</b>
10-32	1/4	5/16	1/8	2-1/2	13/32	1/8
1/4-20	5/16	3/8	3/16	2-1/2	15/32	5/32
5/16-18	3/8	13/32	7/32	2-1/2	5/8	3/16
3/8-16	7/16	15/32	9/32	2-1/2	21/32	7/32
7/16-14	1/2	1/2	5/16	2-1/2	3/4	1/4

[www.sunbeltstudwelding.com](http://www.sunbeltstudwelding.com)

Sunbelt Stud Welding, Inc  
6381 Windfern Road  
Houston, Texas 77040-4915



1-800-462-9353  
713-939-8903  
fax 713-939-9013



# ALUMINUM COLLAR STUDS

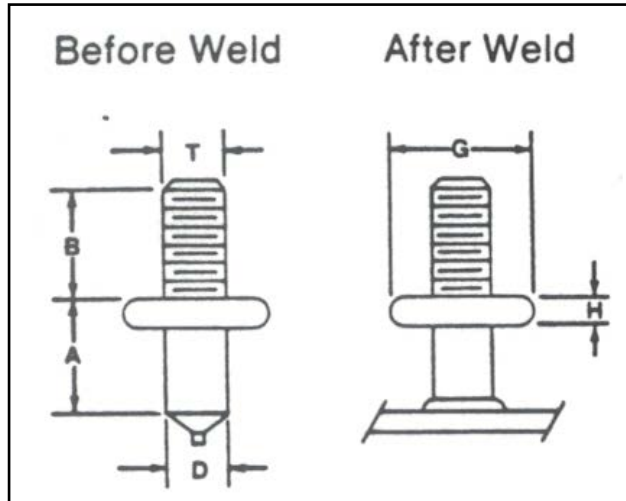

**SUNBELT** aluminum collar studs are partially threaded studs with a collar separating the weld base and thread. They are available in thread diameters from 1/4” through 1/2”.

**Typical Use:** As a spacer between parent metal and part secured on extension. Minimum weld base diameter facilitates welding to lighter gauge parent metal.

**Length Specifications:** Lengths are limited by minimums established by length before weld (BW), of A dimension, and thread length B.

**Material:** Aluminum alloy 5000 Series.

**Ferrules:** All orders include ferrules, which are supplied with the studs and are not sold individually.

**To Order:** Specify CS studs, quantity, D, T, A(BW), B, material.

SPECIFICATIONS						
THREAD SIZE	WELD BASE DIAMETER (NOM.)	MINIMUM LENGTH		MAXIMUM THREADED LENGTH	COLLAR DIAMETER	COLLAR THICKNESS
		BEFORE WELD	AFTER WELD (NOM.)			
T	D	A(BW)	A(AW)	B	G	H
1/4-20	.215	11/16	1/2	1-1/4	1/2	3/32
5/16-18	.275	3/4	9/16	1-1/4	5/8	1/8
3/8-16	.330	3/4	9/16	1-1/4	5/8	1/8
1/2-13	.447	13/16	5/8	1-1/4	3/4	1/8

[www.sunbeltstudwelding.com](http://www.sunbeltstudwelding.com)

Sunbelt Stud Welding, Inc  
 6381 Windfern Road  
 Houston, Texas 77040-4915



1-800-462-9353  
 713-939-8903  
 fax 713-939-9013



# ALUMINUM FB WELDING PINS

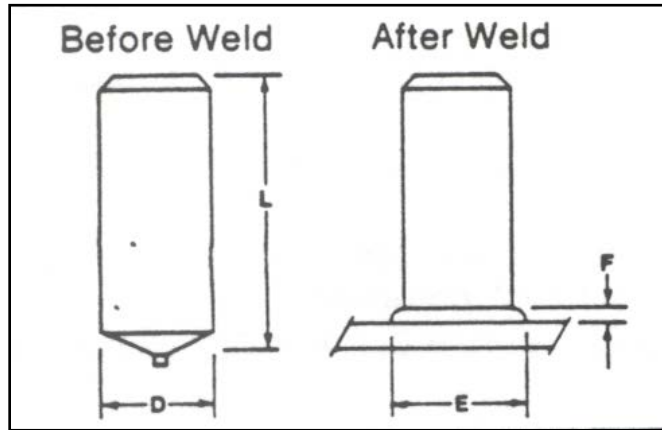

**SUNBELT** aluminum FB (Full Base) welding pins are unthreaded fasteners. They are available in diameters from 1/4” through 1/2”.

**Typical Use:** Heat transfer pins.

**Length Specifications:** Lengths available from minimums shown in specifications.

**Material:** Aluminum alloy 5000 Series.

**Ferrules:** All orders include ferrules, which are supplied with the studs are not sold individually.

**To Order:** Specify **FB**, quantity, **D**, **L(BW)**, material.

SPECIFICATIONS				
WELD BASE DIAMETER (NOM.) <b>D</b>	MINIMUM LENGTH		APPROXIMATE WELD BEAD DIMENSIONS	
	BEFORE WELD	AFTER WELD (NOM.)	DIAMETER <b>E</b>	HEIGHT <b>F</b>
	<b>L(BW)</b>	<b>L(AW)</b>		
1/4	11/16	1/2	13/32	1/8
5/16	11/16	1/2	15/32	5/32
3/8	13/16	5/8	5/8	3/16
7/16	7/8	11/16	21/32	7/32
1/2	7/8	11/16	3/4	1/4

[www.sunbeltstudwelding.com](http://www.sunbeltstudwelding.com)

Sunbelt Stud Welding, Inc  
6381 Windfern Road  
Houston, Texas 77040-4915



1-800-462-9353  
713-939-8903  
fax 713-939-9013



# ALUMINUM SB STUDS

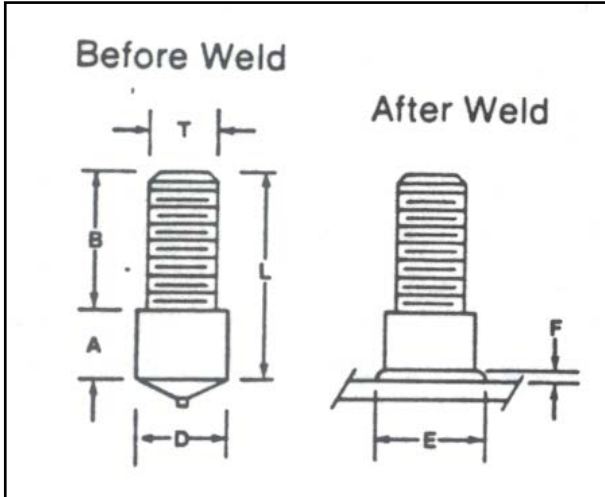

**SUNBELT** aluminum SB (shoulder Base) welding studs are partially threaded studs with a base diameter greater than the thread diameters. Available with weld-base diameters from 5/16” through 1/2”; thread diameters as specified.

**Typical Use:** To provide a spacer between the parent metal and the fastened part.

**Length Specifications:** Overall length limits are established by the combination of A and B.

**Material:** Aluminum alloy 5000 Series.

**Ferrules:** All orders include ferrules, which are supplied with the studs and are not sold individually.

**To Order:** Specify **SB** studs, quantity, **D**, **T**, **A(BW)**, **B**, material.

SPECIFICATIONS								
THREAD SIZE	WELD BASE DIA. (NOM)	UNTHREADED LENGTH		MAX THREAD LENGTH	MAXIMUM OVERALL LENGTH		APPROXIMATE WELD BEAD DIMENSIONS	
		B-4 WELD	AFTER WELD (NOM)		BW	AW	DIA.	HGT.
T	D	A(BW)	A(AW)	B	L(AW)	L(AW)	E	F
10-32	5/16	7/16	1/4	7/16	7/8	11/16	15/32	5/32
1/4-20	3/8	15/32	9/32	5/8	1-3/32	29/32	5/8	3/16
5/16-18	7/16	15/32	9/32	3/4	1-7/32	1-1/32	21/32	7/32
3/8-16	1/2	1/2	5/16	1	1-1/2	1-5/16	3/4	1/4

[www.sunbeltstudwelding.com](http://www.sunbeltstudwelding.com)

Sunbelt Stud Welding, Inc  
 6381 Windfern Road  
 Houston, Texas 77040-4915



1-800-462-9353  
 713-939-8903  
 fax 713-939-9013



## ALUMINUM SB WELDING PINS

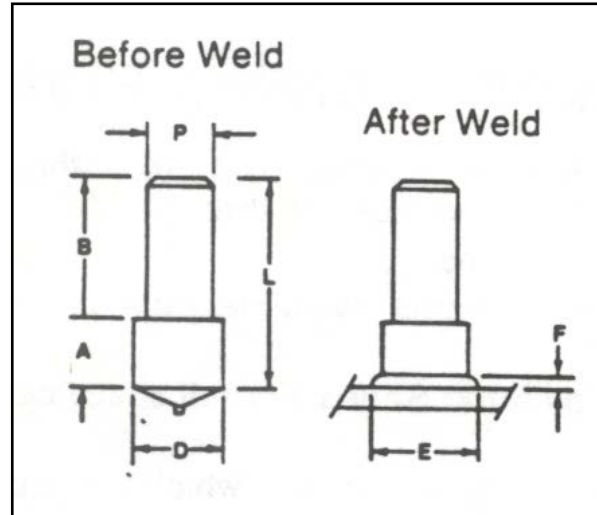

**SUNBELT** aluminum SB (Shoulder Base) welding pins are plain, unthreaded fasteners with a weld base diameter greater than the extension diameter. Available with weld base diameters from 1/4" through 1/2"; extension diameters, 1/8" through 3/8".

**Typical Use:** As standoff and pivot between parent metal and rotating arm or wheel.

**Length Specifications:** Overall length limits are established by the combination of A and B.

**Material:** Aluminum alloy 5000 Series.

**Ferrules:** All orders include ferrules, which are supplied with the studs and are not sold individually.

**To Order:** Specify **SB** pins, quantity, **D, P, A(BW), B**, material.

SPECIFICATIONS								
PIN DIA. <b>P</b>	WELD BASE DIA. (NOM.) <b>D</b>	WELD BASE LENGTH		MAX PIN LENGTH <b>B</b>	MAXIMUM OVERALL LENGTH		APPROXIMATE WELD BEAD DIMENSIONS	
		B-4 WELD <b>A(BW)</b>	AFTER WELD <b>A(AW)</b>		B/W <b>L(BW)</b>	A/W <b>L(AW)</b>	DIA. <b>E</b>	HGT. <b>F</b>
1/8	1/4	5/16	1/8	5/16	5/8	7/16	13/32	1/8
3/16	5/16	3/8	3/16	15/32	27/32	21/32	15/32	5/32
1/4	3/8	13/32	7/32	5/8	1-1/32	25/32	5/8	3/16
5/16	7/16	15/32	9/32	25/32	1-1/4	1-1/16	21/32	7/32
3/8	1/2	1/2	5/16	1	1-1/2	1-5/16	3/4	1/4

[www.sunbeltstudwelding.com](http://www.sunbeltstudwelding.com)

**Sunbelt Stud Welding, Inc**  
6381 Windfern Road  
Houston, Texas 77040-4915



10-5

1-800-462-9353  
713-939-8903  
fax 713-939-9013



# ALUMINUM FB STUDS

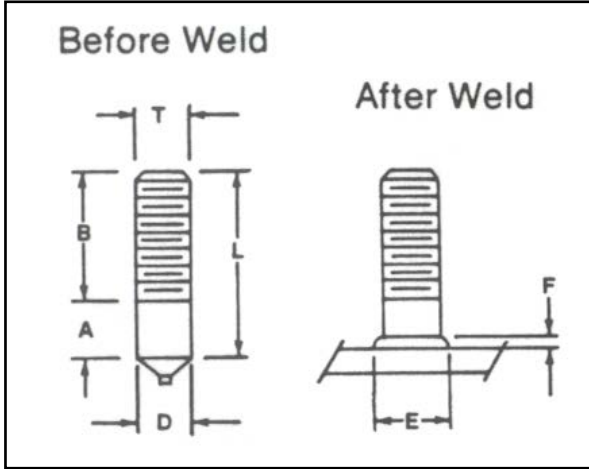

SUNBELT FB aluminum studs, available in diameters from 1/4" to 1/2", have equal weld base and thread diameters.

**Typical Use:** When minimum fillet dimensions are required at the weld base.

**Length Specifications:** Available in minimum weld base heights specified, with a maximum of 1-1/4" thread length.

**Material:** Aluminum alloy 5000 Series; others on request.

**Ferrules:** All orders include ferrules, which are supplied with the studs and are not sold individually.

**To Order:** Specify **FB** studs, quantity, **D**, **L(BW)**, **B**, material.

SPECIFICATIONS								
THREAD SIZE	WELD BASE DIA. (NOM)	MINIMUM WELD BASE HEIGHT		MAX THREAD LENGTH	MINIMUM OVERALL LENGTH		APPROXIMATE WELD BEAD DIMENSIONS	
		B-4 WELD	AFTER WELD (NOM)		B-4 WELD	AFTER WELD	DIA.	HGT.
T	D	A(BW)	A(AW)	B	L(BW)	L(AW)	E	F
1/4-20	1/4	5/16	1/8	1-1/4	13/16	5/8	13/32	1/8
5/16-18	5/16	3/8	3/16	1-1/4	1	13/16	15/32	5/32
3/8-16	3/8	13/32	7/32	1-1/4	1-5/32	31/32	5/8	3/16
7/16-14	7/16	15/32	9/32	1-1/4	1-11/32	1-5/32	21/32	7/32
1/2-13	1/2	3/8	3/16	1-1/4	1-1/2	1-5/16	3/4	1/4

[www.sunbeltstudwelding.com](http://www.sunbeltstudwelding.com)

Sunbelt Stud Welding, Inc  
 6381 Windfern Road  
 Houston, Texas 77040-4915



1-800-462-9353  
 713-939-8903  
 fax 713-939-9013