

# CD Studs - Pin Bi-Metallic

## CD STUDS: PIN BI-METALLIC

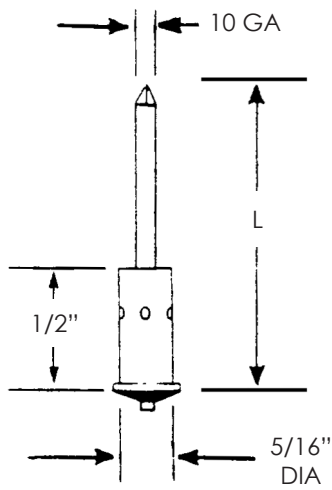

<b>MATERIAL</b>	PIN Stainless Steel	BASE Aluminum - (5000 Series)
<b>WASHER</b>	Self-Locking washers are available in a variety of sizes, shapes and materials.	

To order or specify give: Product Code, Material and Quantity  
Example: CB BM-P, Stainless Steel, 1000 pcs.

See **Accessories** for accessory details. See **CD Stud Welding General Information** and **Technical Details** for process description, material combinations, reverse-side marking, locating options, technical details, guidelines, torque values, weight charts and standard stock sizes.



website [www.sunbeltstudwelding.com](http://www.sunbeltstudwelding.com) email [info@sunbeltstudwelding.com](mailto:info@sunbeltstudwelding.com)  
6381 Windfern Road, Houston, TX 77040 telephone 1.800.462.9353 - Houston 713.939.8903 fax 713.939.9013

# CD Studs - Annular Ring Bi-Metallic

## CD STUDS: ANNULAR RING BI-METALLIC

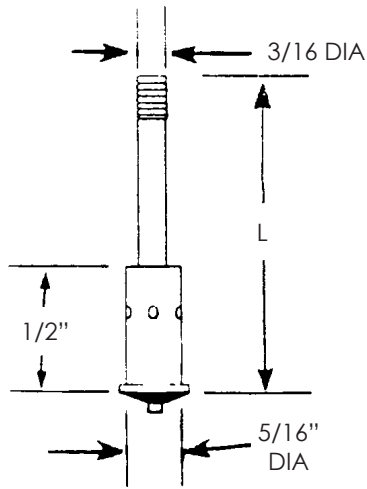

<b>MATERIAL</b>	PIN Stainless Steel	BASE Aluminum - (5000 Series)
<b>CAP</b>	The cap for use with this stud is the WCNAR CAP, annular ring cap.	

To order or specify give: Product Code, Material and Quantity  
Example: CD BM-AR, Stainless Steel, 1000 pcs.

See **Accessories** for accessory details. See **CD Stud Welding General Information** and **Technical Details** for process description, material combinations, reverse-side marking, locating options, technical details, guidelines, torque values, weight charts and standard stock sizes.



website [www.sunbeltstudwelding.com](http://www.sunbeltstudwelding.com) email [info@sunbeltstudwelding.com](mailto:info@sunbeltstudwelding.com)  
6381 Windfern Road, Houston, TX 77040 telephone 1.800.462.9353 - Houston 713.939.8903 fax 713.939.9013

# CD Studs - Notched End Bi-Metallic

## CD STUDS: NOTCHED END BI-METALLIC

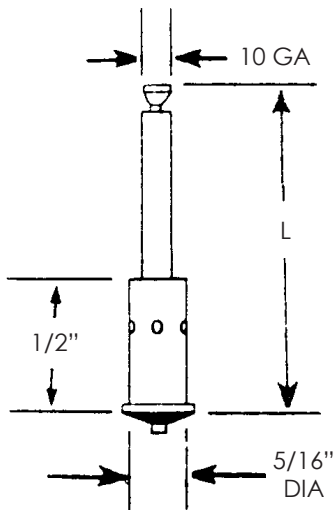

<b>MATERIAL</b>	PIN Stainless Steel	BASE Aluminum - (5000 Series)
<b>WASHER</b>	The washer for use with this stud is the WCN NE KHS, notched and keyhole slotted washer.	

To order or specify give: Product Code, Material and Quantity  
Example: CD BM-NE, Stainless Steel, 1000 pcs.

See **Accessories** for accessory details. See **CD Stud Welding General Information** and **Technical Details** for process description, material combinations, reverse-side marking, locating options, technical details, guidelines, torque values, weight charts and standard stock sizes.



website [www.sunbeltstudwelding.com](http://www.sunbeltstudwelding.com) email [info@sunbeltstudwelding.com](mailto:info@sunbeltstudwelding.com)  
6381 Windfern Road, Houston, TX 77040 telephone 1.800.462.9353 - Houston 713.939.8903 fax 713.939.9013