

Cable Hanger - Banding Type

CABLE HANGERS: BANDING-TYPE

Shipbuiding/Offshore: Cable Hanger: Banding Type: Type 7: Stamped Ferrule Option

Note: Stamped Ferrule Dimensions Typical only.
Complete 180 degrees arc required.

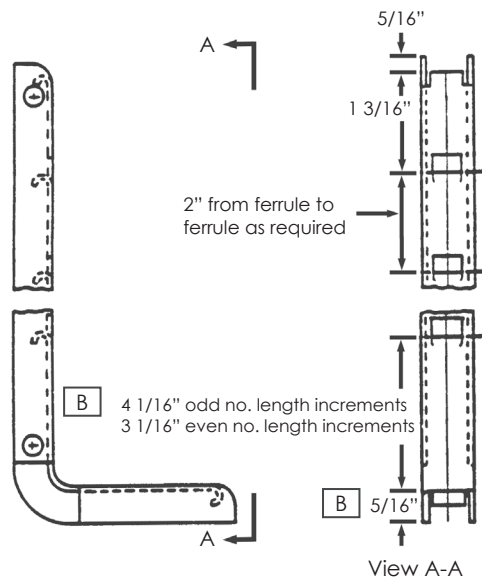

Shipbuiding/Offshore: Cable Hangers Banding Type - Type 8: Stamped Ferrule Option

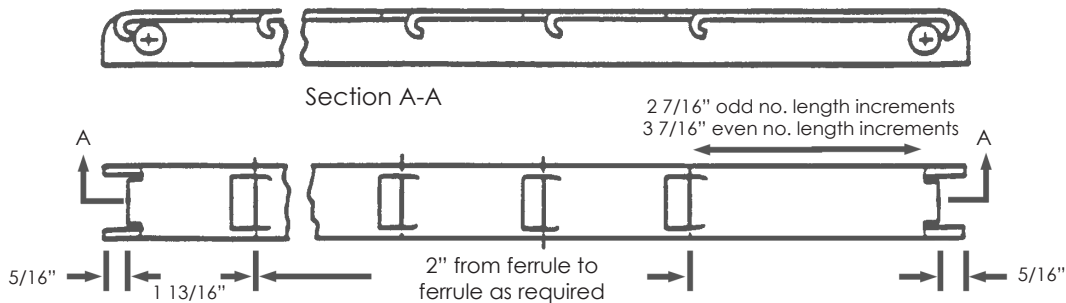

1. Also, all banding hangers, Types 2, 3, 7, 8, 19 and 20 can be manufactured in strict accordance with Buships DWG. 302-1716084.

2. All banding hanger ferrules, PC. NOS. 1361, 1362, 1363, and 1367 manufactured in strict accordance with Buships DWG. 9000-S6202-73980, section 1, sheet 36.

3. All banding hanger slotting is on 2" centers for types 7 and 8 and on 2" centers for types 2 and 3.

4. Finish:

(a) banding hangers, types 2, 3, 7 and 8 - military yellow zinc chromate.

(b) banding hangers, type 19 and 20 - zinc plated.

Note: Hanger accessory items shown on this page are commonly used for main and local wire way runs aboard submarines. However these items are not restricted to that end use.

All hangers are intended for use with standard 3/8" shouldered welding studs.

